

OEM Relative and absolute pressure transmitter type 515

Pressure range
-1 ... 0 – 600 bar



Type 515 pressure transmitter with cable connection meets the highest demands for industry and vehicle manufacturing applications.

The compact and robust mechanical design incorporating protection standard IP69K allows the use in stringent conditions.

- Compact, rugged construction for highest operational reliability
- Negligible temperature influence on accuracy
- Excellent EMC capacity

Technical overview

Pressure range ¹⁾

Relative	-1 ... 0 – 600 bar
Absolute	0 ... 25 bar

Operating conditions

Medium	Liquids	
Temperature	FPM	-15 ... +125 °C
	EPDM	-25 ... +125 °C
	NBR	-25 ... +85 °C
	FPM spec.	-40 ... +150 °C
	Ambient	max. +85 °C
Tolerable overload / Rupture pressure ²⁾	< 6	3.0 x fs
	≥ 6	2.5 x fs (max. 900 bar)

Materials

Case	Stainless steel 1.4305 / AISI 303	
Materials in contact with the medium	Pressure connection	Stainless steel 1.4305 / AISI 303
	Sensor	Ceramic Al ₂ O ₃ (96%)
	Media stop system	PPS
	Sealing material	FPM, EPDM, NBR, FPM spec.

Media stop system

Patented media stop system to prevent media egress when exceeding rupture pressure range (> 40 bar nominal value).

Electrical overview

	Output	Power supply	Load	Current consumption ³⁾
2 wire	4 ... 20 mA	8.0 ... 33 VDC	< $\frac{\text{supply voltage} - 8 \text{ V}}{0.02 \text{ A}}$ [Ohm]	< 20 mA
	0 ... 5 V	8.0 ... 33 VDC	>10 kOhm / < 100 nF	< 4 mA
3 wire	1 ... 6 V	8.0 ... 33 VDC	>10 kOhm / < 100 nF	< 4 mA
	0 ... 10 V	11.4 ... 33 VDC	>10 kOhm / < 100 nF	< 4 mA
	0 ... 10 V	24 VAC ±15%	>10 kOhm / < 100 nF	< 4 mA
	ration. 10 ... 90%	5 VDC ±5%	>10 kOhm / < 100 nF	< 4 mA
Polarity reversal protection	Short circuit proof and protected against polarity reversal. Each connection is protected against crossover up to max. supply voltage.			
Insulation voltage			standard	500 VDC
			optional	1000 VDC

Dynamic response

Response time	< 2 ms, typ. 1 ms
Load cycle	< 100 Hz

Protection standard

IP 69K

Electrical connection

Cable PUR 1.5 m

Pressure connection

Inside thread	G ¼, with O-Ring seal
	G ¼, sealed at back, DIN 3852-E
Outside thread	G ½, sealed at front
	G ½, sealed at back and manometer (combi)
	¼, -18 NPT
	R ¼, EN 10226
	M12x1.5 sealed at back, DIN 3852-E
	M14x1.5 sealed at back, DIN 3852-E

Installation arrangement

Unrestricted

Tests / Admissions

Electromagnetic compatibility	CE conformity acc. EN 61326-2-3
Shock acc. IEC 60068-2-27	40 g, 6 ms half sine wave, all 3 directions. Free fall from 2 m on concrete (6x)
Constant shock acc. IEC 60068-2-29	40 g for 6 ms, 1000 x all 3 directions
Vibration acc. IEC 60068-2-6	25 g, 2 ... 2000 Hz with amplitude ± 15 mm, 1 Octave/min. all 3 directions, 50 constant load

Weight

With thread G ½	~ 225 g
All other versions	~ 180 g

Packaging (Please state on order)

Single packaging in cardboard
Multiple packaging in cardboard per 25 pcs.

Accuracy

Parameter		Unit	
Tolerance zero point	max.	% fs	± 0.3
Tolerance full scale	max.	% fs	± 0.3
Resolution		% fs	0.1
Total of linearity, hysteresis and repeatability	max.	% fs	± 0.3
Long term stability acc. DIN EN 60770		% fs	± 0.5
TC zero point ⁴⁾	max.	% fs/10K	± 0.15
TC sensitivity ⁴⁾	max.	% fs/10K	0/-0.3

Test conditions: 25 °C, 45% RH, power supply 24 VDC
TC z.p. / TC s. -25 ... +85 °C

¹⁾ Other pressure range on request

²⁾ Other overload and Rupture pressure on request

³⁾ At nominal pressure

⁴⁾ TC = Temperature coefficient

Order code selection table in bar		1	2	3	4	5	6	7	8	9	10
		515.	X	X	X	X	X	X	X	X	X
Pressure mode	Relative	9									
	Absolute	8									
Pressure range ¹⁾	-1 ... 0 bar	9	0	0							
	0 ... 1 bar		1	1							
	0 ... 1.6 bar		1	2							
	0 ... 2.5 bar		1	4							
	0 ... 4 bar		1	5							
	0 ... 6 bar		1	7							
	0 ... 10 bar		3	0							
	0 ... 16 bar		3	1							
	0 ... 25 bar		3	2							
	0 ... 40 bar	9	3	3							2
	0 ... 60 bar	9	4	0							2
	0 ... 100 bar	9	4	1							2,5
	0 ... 160 bar	9	4	2							2,5
	0 ... 250 bar	9	4	3							2,5
	0 ... 400 bar	9	5	4	6						2,5
0 ... 600 bar	9	5	5	6						2,5	
▲ Full scale signal at these pressures											
Sealing material ²⁾	FPM	Fluoro elastomer				0					
	EPDM	Ethylene propylene				1					
	NBR	Butadiene Acrylonitrile				2					
	FPM spec.	Fluoro elastomer spec.				6					
Adjustment	Factory					0					
Output / power supply	0 ... 5 V	8.0 ... 33 VDC					1				
	1 ... 6 V	8.0 ... 33 VDC					6				
	0 ... 10 V	11.4 ... 33 VDC					2				
	4 ... 20 mA	8.0 ... 33 VDC					3				
	ration. 10 ... 90%	5 VDC ±5%					4				
Electrical connection	Cable 1.5 m PUR							0			
Pressure connection ³⁾	Inside thread	G ¼ mit O-Ring seal								1	
		G ¼ sealed at back, DIN 3852-E								4	
		G ½ sealed at front								9	
	Outside thread	G ½ sealed at back and manometer (combi)								8	
		¼ -18 NPT								3	
		R ¼, EN 10226								7	
		M12x1.5 sealed at back, DIN 3852-E								5	
M14x1.5 sealed at back, DIN 3852-E								6			
Version	Stainless steel	without media stopper								1	
		with media stopper (standard from 40 bar)								2	
		with pressure tip orifice (from 100 bar on)								5	
Pressure range variation (optional)	Indicate W and state range on order (e.g.: W0... + 8bar/OUT1...9V)										
W											

Order code selection table in psi		1	2	3	4	5	6	7	8	9	10
		515.	X	X	X	X	X	X	X	X	X
Pressure mode	Relative	9									
	Absolute	8									
Pressure range ¹⁾	-30 ... 0" hg	9	A	0							
	0 ... 15 psi		B	1							
	0 ... 30 psi		B	4							
	0 ... 60 psi		B	5							
	0 ... 100 psi		B	7							
	0 ... 200 psi		C	1							
	0 ... 300 psi		C	2							
	0 ... 500 psi	9	C	3							2
	0 ... 750 psi	9	D	0							2
	0 ... 1000 psi	9	D	1							2,5
	0 ... 2000 psi	9	D	2							2,5
	0 ... 3000 psi	9	D	3							2,5
	0 ... 5000 psi	9	E	4	6						2,5
	0 ... 7500 psi	9	E	5	6						2,5
	▲ Full scale signal at these pressures										
Sealing material ²⁾	FPM	Fluoro elastomer				0					
	EPDM	Ethylene propylene				1					
	NBR	Butadiene Acrylonitrile				2					
	FPM spec.	Fluoro elastomer spec.				6					
Adjustment	Factory					0					
Output / power supply	0 ... 5 V	8.0 ... 33 VDC					1				
	1 ... 6 V	8.0 ... 33 VDC					6				
	0 ... 10 V	11.4 ... 33 VDC					2				
	4 ... 20 mA	8.0 ... 33 VDC					3				
	ration. 10 ... 90%	5 VDC ±5%					4				
Electrical connection	Cable 1.5 m PUR							0			
Pressure connection ³⁾	Inside thread	G ¼ mit O-Ring seal								1	
		G ¼ sealed at back, DIN 3852-E								4	
		G ½ sealed at front								9	
	Outside thread	G ½ sealed at back and manometer (combi)								8	
		¼ -18 NPT								3	
		R ¼, EN 10226								7	
		M12x1.5 sealed at back, DIN 3852-E								5	
M14x1.5 sealed at back, DIN 3852-E								6			
Version	Stainless steel	without media stopper								1	
		with media stopper (standard from 750 psi)								2	
		with pressure tip orifice (from 2000 psi on)								5	
Pressure range variation (optional)	Indicate W and state range on order (e.g.: W0... + 120psi/OUT1...9V)										
W											

¹⁾ Other pressure ranges on request

²⁾ Other sealing material on request

³⁾ Other pressure connection on request

Order code selection table in MPa			1	2	3	4	5	6	7	8	9	10	
			515.	X	X	X	X	X	X	X	X	X	
Pressure mode	Relative		9										
	Absolute		8										
Pressure range ¹⁾	-0.1 ... 0 MPa		9	F	0								
	0 ... 0.1 MPa			G	1								
	0 ... 0.16 MPa			G	2								
	0 ... 0.25 MPa			G	4								
	0 ... 0.4 MPa			G	5								
	0 ... 0.6 MPa			G	7								
	0 ... 1 MPa			H	0								
	0 ... 1.6 MPa			H	1								
	0 ... 2.5 MPa			H	2								
	0 ... 4 MPa		9	H	3							2	
	0 ... 6 MPa		9	K	0							2	
	0 ... 10 MPa		9	K	1							2,5	
	0 ... 16 MPa		9	K	2							2,5	
	0 ... 25 MPa		9	K	3							2,5	
	0 ... 40 MPa	FPM spec. seal only	9	L	4	6						2,5	
	0 ... 60 MPa	FPM spec. seal only	9	L	5	6						2,5	
	▲ Full scale signal at these pressures												
Sealing material ²⁾	FPM	Fluoro elastomer				0							
	EPDM	Ethylene propylene				1							
	NBR	Butadiene Acrylonitrile				2							
	FPM spec.	Fluoro elastomer spec.				6							
Adjustment	Factory						0						
Output / power supply	0 ... 5 V	8.0 ... 33 VDC							1				
	1 ... 6 V	8.0 ... 33 VDC							6				
	0 ... 10 V	11.4 ... 33 VDC							2				
	4 ... 20 mA	8.0 ... 33 VDC							3				
	ration. 10 ... 90%	5 VDC ±5%							4				
Electrical connection	Cable 1.5 m PUR									0			
Pressure connection ³⁾	Inside thread	G ¼ mit O-Ring seal										1	
		G ¼ sealed at back, DIN 3852-E										4	
		G ½ sealed at front										9	
	Outside thread	G ½ sealed at back and manometer (combi)											8
		¼ -18 NPT											3
		R ¼, EN 10226											7
		M12x1.5 sealed at back, DIN 3852-E											5
M14x1.5 sealed at back, DIN 3852-E											6		
Version	Stainless steel	without media stopper										1	
		with media stopper (standard from 4 MPa)										2	
		with pressure tip orifice (from 10 MPa on)										5	
Pressure range variation (optional)	Indicate W and state range on order (e.g.: W0... + 0.8MPa/OUT1...9V)											W	

¹⁾ Other pressure ranges on request

²⁾ Other sealing material on request

³⁾ Other pressure connection on request

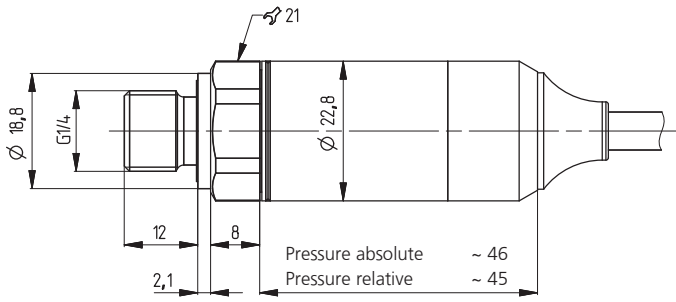

2-wire
(4 ... 20 mA)

3-wire

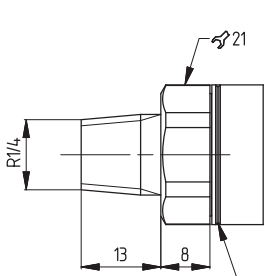
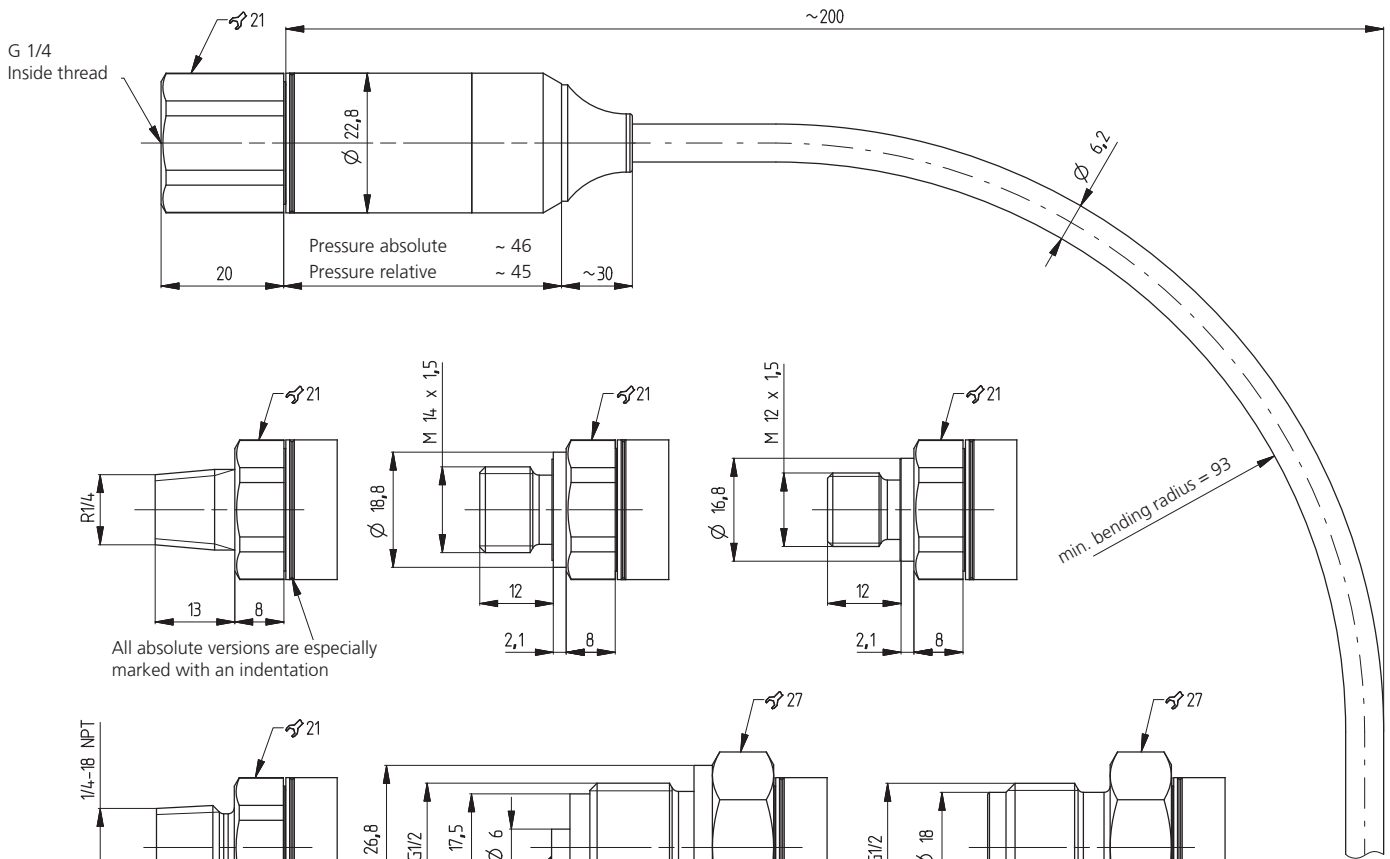
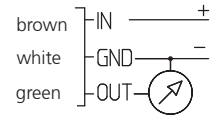
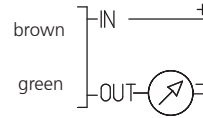

All absolute versions are especially marked with an indentation

